

DS02-031

2016-2021 Dodge Ram 1500/2500/3500 Crew Cabs Installation Instructions

Hardware Kit Includes Loose:

- (1) 12 – Hex head bolts (M8-1.25 x 30mm) Grade 8.8
- (2) 12 – Hex head Nuts (M8-1.25) Grade 8.8
- (3) 30 – Lock washers (M8) Grade 8.8
- (4) 30 – Flat washers (M8) Grade 8.8
- (5) 4 – M8 Fender washers
- (6) 6 – Hex head bolts (M8-1.25 x 20mm) Grade 8.8
- (7) 6 – M10-1.5 Hex head nuts Grade 8.8
- (8) 6 – M10 Flat Washer Grade 8.8
- (9) 6 – M10 Lock Washer Grade 8.8
- (10) 6 – M10 Plastic push nuts
- (11) 12 – M8 Plastic push nuts

Components List:

- (1) – Driver/Passenger Drop Steps
- (2) – (4) Front/Middle Mounting Brackets (RTSPN089)
- (3) – (2) Rear Mounting Brackets (RTSPN090)
- (4) – (6) M8-1.25 Triple T-bolt
- (5) – (6) M10-1.5x 40mm Single T-bolts
- (6) – (6) M8 RT Step T Bolt (RTSPN175)

**LOOSE FIT ALL COMPONENTS.
DO NOT TIGHTEN UNTIL ALL
COMPONENTS ARE INSTALLED
AND ADJUSTED.**

**DISCLAIMER: USE ONLY COMPONENTS
AND HARDWARE SUPPLIED .
NO SUBSTITUTIONS.**

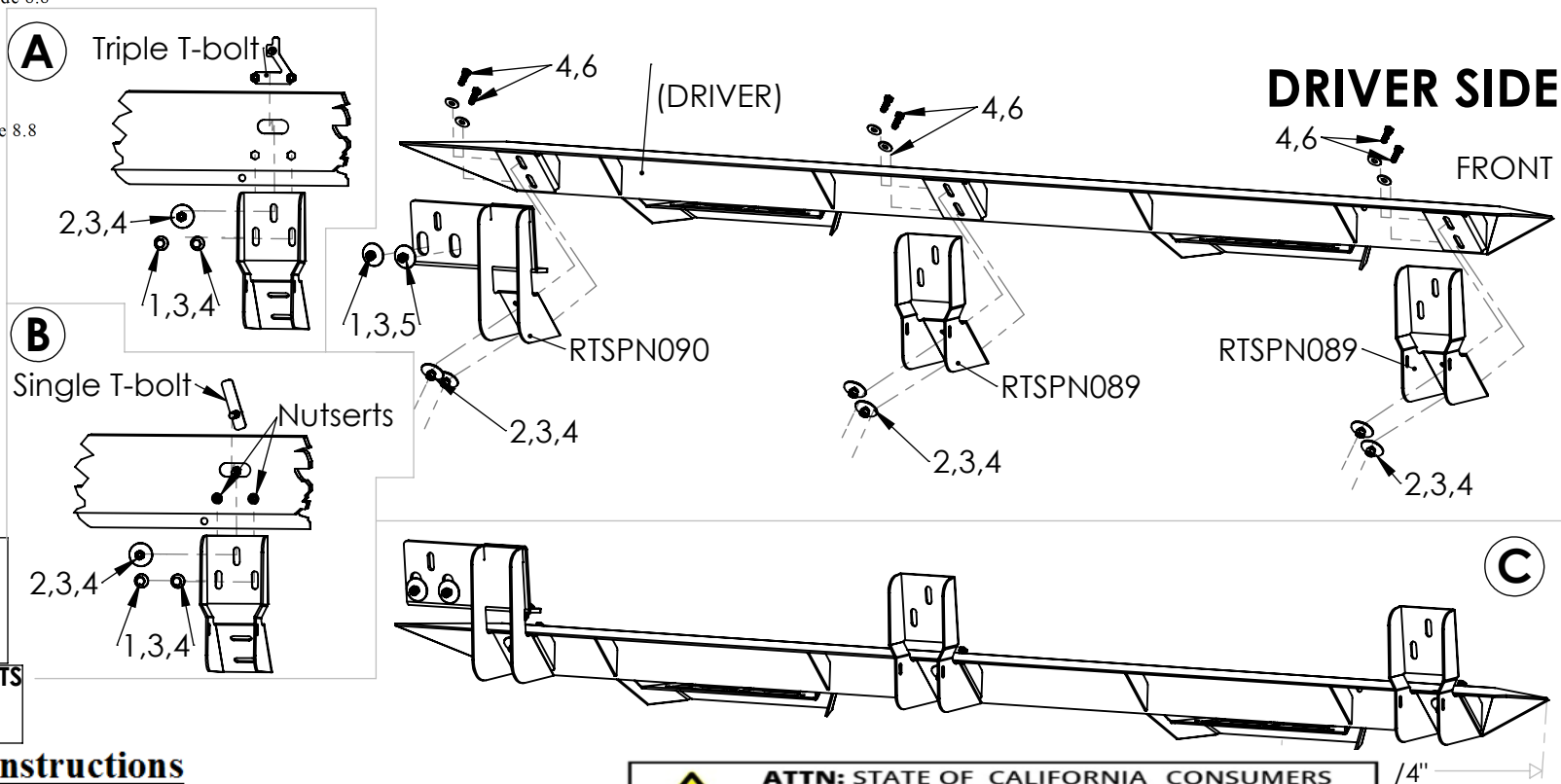

Step by Step Installation Instructions

- STEP 1:** Read and understand instructions completely before beginning installation.
- STEP 2:** Remove all factory step brackets and hardware. If your truck was equipped with factory steps and you have threaded Nutserts in the inside rocker panel, leave Nutserts in the panel.
- STEP 3:** Locate the driver's side step and rear bracket (the center of the front foot step is 23.25" from the front of the bar).
- STEP 4:** Using figures A & B, determine if your truck has the threaded Nutserts in the lower inside rocker panel or not. If your truck is equipped with them, then you will use the single t-bolt set up as shown in figure B in the top hole location. If your truck does not have the Nutserts, then use the triple t-bolt as shown in figure A. Once you have determined which t-bolt to use, insert t-bolts with supplied square plastic washers (put plastic washers on t-bolts before installing so they don't fall into rocker panel). Loose fit brackets to rocker panel using supplied hardware (see FIG A or B).
- STEP 5:** Once bar and support strap are loose fit to truck, loose fit steps to brackets using supplied hardware.
- STEP 6:** Once bar and brackets have been loose fit into position, adjust and tighten the brackets to rocker panel. If using factory Nutserts, tighten by hand and do not over tighten. If using triple t-bolt, fully tighten by hand and **Do not use impact tools.**
- STEP 7:** Next, adjust bar front/back and up/down then tighten steps to brackets. Fully tighten hardware attaching the step to the brackets. **Do not use impact tools.** Repeat for passenger side.



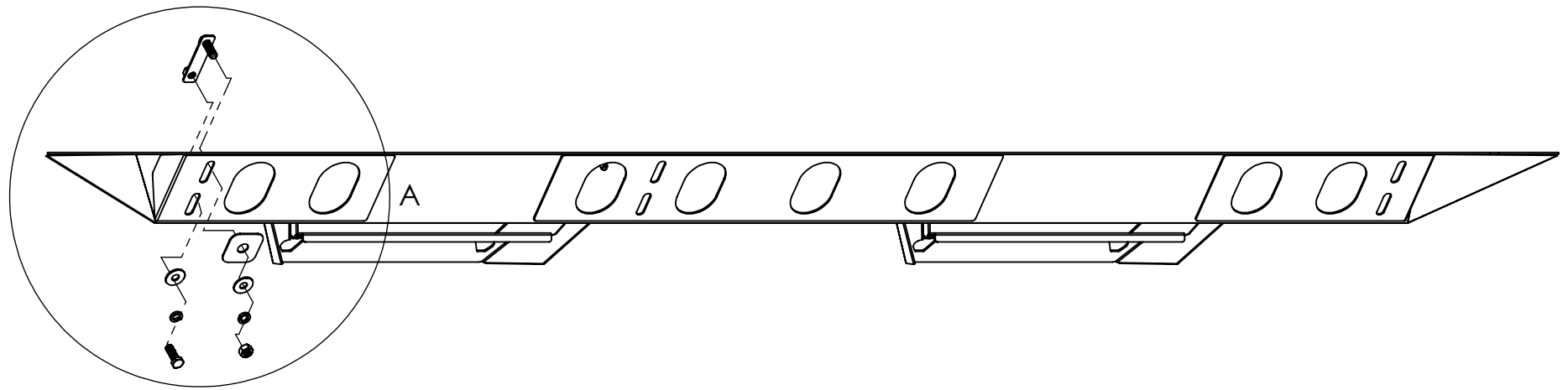

RTSPN175 - M8 RT STEP
MOUNTING T-BOLT

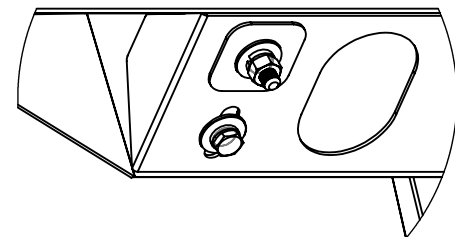
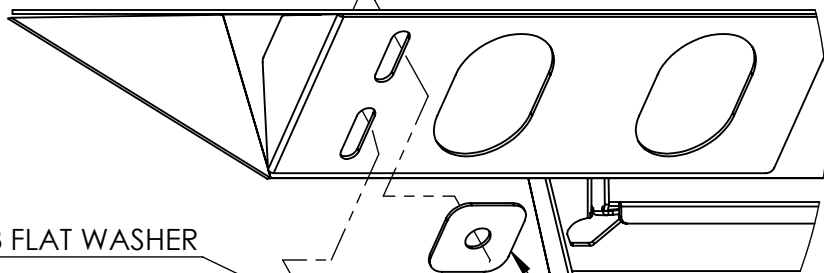
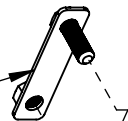

M8 FLAT WASHER



M8 LOCK WASHER



M8-1.25 x 20MM
HEX HEAD BOLT



M8 PLASTIC PUSH NUT



M8 FLAT WASHER



M8 LOCK WASHER



M8-1.25 HEX HEAD NUT

